



GENERAL SUPPLEMENTAL SPECIFICATIONS TO THE SUDAS STANDARD SPECIFICATIONS, CURRENT EDITION

Effective Date: February 16, 2016

This project will be constructed in accordance with the Current Edition of the Iowa Statewide Urban Standard Specifications for Public Improvements Manual (SUDAS) which was adopted by the Board of Trustees of the West Des Moines Water Works, on November 16, 2015, as further revised by these General Supplemental Specifications.

The Iowa Statewide Urban Standard Specifications for Public Improvements Manual (SUDAS) may be viewed at the Iowa SUDAS website <http://www.iowasudas.org> or can be purchased only from:

Statewide Urban Design and Specifications
2711 S. Loop Drive, Suite 4700
Ames, IA 50010
515-294-2869
brich@iastate.edu

Said SUDAS Standard Specifications as adopted for West Des Moines Water Works projects are hereby amended as follows:

DIVISION 1 – GENERAL PROVISIONS AND COVENANTS

Section 1010 – General Conditions

Part 1.03 – Definitions and Terms – Add the following definitions and terms.

BOARD OF TRUSTEES. The governing body of the West Des Moines Water Works as constituted under Iowa Code Chapter 388.

CITY. The City of West Des Moines, Iowa.

WATER WORKS. The West Des Moines Water Works, acting through its Board of Trustees. The terms “Jurisdiction” and “Water Works” are used interchangeably in these Modifications.

Section 1015 – Water Works Plan Submittal Requirements (New Section)

Part 1.01 – General Requirements

- A. Design water mains and appurtenances in accordance with the following standards:
 - 1. Iowa Department of Natural Resources Standards and Requirements
 - 2. SUDAS Design Manual, current edition
 - 3. City of West Des Moines Comprehensive Plan
- B. Submit plans of proposed construction for review and approval prior to commencing construction activities.
 - 1. Water Works – Submit plans to the Engineering Project Manager, West Des Moines Water Works, 4200 Mills Civic Parkway, Suite 1D, West Des Moines, Iowa 50265.

- a. Plan should be certified by a registered professional engineer as contemplated by Chapter 542B, Code of Iowa.
 - b. Review submittal should include one (1) printed copy.
 - c. Final submittal should include three (3) printed copies and a PDF of the drawings.
 2. Iowa Department of Natural Resources – The Developer, subdivider or property owner is responsible to submit plans to Iowa DNR and to pay all applicable fees. Copy Water Works on all submittals.
 - a. Submit one (1) copy of the Iowa DNR Water Supply Section Construction Permit Application and applicable schedules.
 - b. Submit one (1) copy of the Iowa DNR Water Supply Service Agreement.
 3. City of West Des Moines – Certain projects with water infrastructure may require City of West Des Moines approval. Contact the City of West Des Moines, Development Services Department for additional information.
 4. Other Approvals – Certain projects may require the applicant to obtain permits from other entities. These may include, but are not limited to, the Iowa Department of Transportation, the US Army Corps of Engineers, and Railroad companies.
- C. Do not begin work or make connection to the existing water distribution system until all required permits have been received and Water Works has approved construction plans, unless otherwise authorized by Water Works.
- D. Excavation, pipe laying, backfilling, testing and disinfecting of water mains, water service connections and all appurtenances will be subject to inspection by a representative of the Water Works to ensure compliance with specifications.
- E. The cost of inspection and testing as set out in Water Works Resolutions shall be paid prior to acceptance of the work by the Water Works, or if the work is to remain privately owned, prior to the first occupancy of the building or site.

Part 1.02 – Information for the Water Works

- A. A minimum of seven (7) calendar days prior to beginning construction, provide two (2) copies of the following:
1. Certificates of Insurance as required by Section 1070, Part 3.
 2. Railroad Protective Liability Insurance, if appropriate.
 3. Copies of approved permits required for the project.

Part 1.03 – Information for the Water Works following construction

- A. After construction is complete, provide the following information. Information shall be provided to the Water Works prior to acceptance of the work by the Water Works, or if the work is to remain privately owned, prior to the first occupancy of the building or site.
1. Provide As-Built Drawings (to scale) at either 11"x17" or 12"x18" size in the following formats:
 - a. One (1) copy printed on 0.004" minimum thickness mylar.
 - b. One (1) PDF copy submitted on either CD or DVD.
 - c. One (1) copy of Microstation DGN files submitted on either CD or DVD.
 2. Field measurements to aid in the location of curb stops installed on the project. Measurements should be made to lot corners or other permanent monuments.
 3. Additional requirements for work which Water Works will accept ownership and maintenance responsibility.
 - a. Two (2) copies of Maintenance Bond as required by Section 1070, Part 3.

- b. One (1) copy of a tabulation showing installed lengths and costs of each diameter of water main and the number and total cost of hydrants installed. Pipe cost should include the costs of valves, valve boxes, fittings and other items appropriate to each diameter of pipe. Tabulation should total 100% of value of work, except for water service and fire protection connections.

Section 1020 – Proposal Requirements and Conditions

Part 1.08 – Taxes

Delete A. Sales and Use Tax. West Des Moines Water Works will issue Sales Tax Exemption Certificates per 1020-1.08-B for West Des Moines Water Works Projects.

Section 1030 – Approval for Award and Award of Contract

Part 1.03 – Award of Contract

Add the following new E.

- E. Water Works will furnish five (5) sets of Contract Documents after execution of the Contract. If additional contract documents are required, the Contractor shall compensate Water Works for printing costs.

Section 1050 – Control of Work

Part 1.03 – Cooperation by the Contractor

Add the following new E – H.

- E. The Contractor shall provide one (1) set of the Contract Documents and the SUDAS Manual to each foreman or superintendent in charge of each crew on the project.
- F. Cooperate with local governmental agencies; secure necessary permits and arrange for inspections at proper time.
- G. Coordinate all water main and service relocation, transfer and/or replacement with Water Works to notify residents and businesses, in writing, at least two (2) working days in advance when construction will disrupt or block access to their property. Cooperate with Water Works and business owners to schedule work to minimize their access to businesses that may be disrupted. Weekend work or work outside normal work hours may be considered with written approval by Water Works.
- H. The Contractor shall coordinate all operation of Water Valves with the Water Works. The Contractor shall not operate any valves without the prior approval of the Water Works.

Part 1.07 – Examination of Materials and Work

Add the following new C & D.

- C. All materials are subject to inspection and rejection at the site by Water Works.
- D. Laboratory materials tests shall be accomplished by an independent testing laboratory.

Part 1.11 – Providing Job Site Utilities

Add the following new A.1.

1. The Contractors shall not use metered water from any source without the written consent of the private owner. Any such agreements must be filed with the Water Works prior to water usage.

Add the following new B.1.

1. Fire hydrant use shall only be permitted through a hydrant meter backflow unit from the West Des Moines Water Treatment Plant. **Unmetered use of water will not be allowed.** The contractor will be responsible for applicable hydrant meter deposits.

Section 1070 – Legal Relations and Responsibility to the Public

Part 2.06 – Traffic Control

Add the following new A.1 and A.2

1. Install orange safety fence around all excavations as specified hereinafter; maintain safety fence in tight and sound condition; install safety fence suitable distances from excavation to reasonably prevent persons from falling into excavations or having access to spoil piles.
2. The Contractor shall be responsible for sufficiently restraining all traffic control devices used on the project to prevent movement by wind or other natural forces.

Part 2.06 – Traffic Control

Add the following new C – D.

- C. Certain construction operations may require restricting traffic movements or closing streets; arrange work to minimize effects on pedestrian and vehicular traffic.
 1. The Contractor shall submit lane closure layouts and traffic control plans to the Traffic Division of the City of West Des Moines Public Works Department (515.222.3480) a minimum of 48 hours prior to the desired closure of any traffic lanes.
 - a. Provide Water Works with two (2) copies of approved Traffic Control Plan and Lane Closure Layouts. No work will be allowed until copies are received.
 2. Submit detour plans (vehicular and pedestrian as applicable) to the Water Works prior to implementing detour.
- D. Payment for Traffic Control
 1. Unless otherwise indicated, Traffic Control, including the development and implementation of the approved traffic control plan, shall be incidental to the project. This includes all labor, materials, equipment, barricades, signs, safety fence, flashers, flaggers, and other miscellaneous work.

Part 2.15 – Finishing and Cleanup Requirements

Add the following to this section.

At a minimum, the following clean-up requirements apply to work on the project:

Daily – General clean-up of the area in which work took place, including cleaning of paved surfaces, piling of debris in neat piles at reasonable locations as agreed by the Water Works, and securing materials against unintended movement.

Periodic – The Contractor may be requested to perform periodic site clean-up depending on weather and dust conditions. This includes machine broom cleaning of paved surfaces and removal of equipment debris and other material no longer needed for the remainder of the project.

Final – Upon completion of the work, the Contractor shall remove all of its equipment, return the area of work to a neat and clean condition, and do other cleaning necessary to complete the work in a workmanlike manner satisfactory to the Water Works.

Section 1080 – Prosecution and Progress

Part 1.03 – Work Progress and Schedule

Add the following new D & E.

- D. No person shall operate or permit the operation of any tools or equipment in construction, demolition, drilling or preventative maintenance work between the hours of 10:00 p.m. and 7:00 a.m. without the prior written permission of the Water Works.

- E. Clean up and provide surface restoration and surfacing replacement as construction progresses as specified herein.

Part 1.09 – Extension of Time

Insert the following sentence after the second sentence of paragraph B.

The request shall include clear, concise reasons for requesting an extension; provide relevant data to support the extension request.

Insert the following sentence at the end of paragraph B.2. Other Contractors.

Other Contractors shall not be interpreted to include the Contractor's sub-contractors

Delete paragraph D and replace with the following paragraph D.

- D. **Extension of Time Granted:** No extension of time shall be granted or recognized except as specifically approved by the General Manager of West Des Moines Water Works in writing to the Contractor. Oral representations or agreements by Water Works agents or employees regarding time extension shall not be binding on the Water Works.

DIVISION 2 – EARTHWORK

No modifications

DIVISION 3 – TRENCH, BACKFILLING AND TUNNELLING

Section 3010 – Trench and Backfill

Part 3.01 – Trench Excavation

Add the following new E – G.

- E. Trees, Plantings and Shrubbery – Remove or modify trees, plantings and shrubbery only with prior written authorization of Water Works, except for trees marked for removal or modification on plans. Excavate by hand under tree roots 2" diameter and larger.
 - 1. Cut tree roots larger than 2" diameter only when authorized by Water Works. Cut such roots with a saw; do not pull or tear the roots.
 - 2. Conform with City's Tree Ordinance and associated forestry rules.

- F. Backfill trench immediately after Water Works has recorded location of connections and appurtenances and after Water Works has inspected the work.

1. The Contractor shall leave connections and appurtenances exposed until the location has been recorded by West Des Moines Water Works. Connections and appurtenances which are backfilled prior to Water Works inspection and recording of locations are subject to re-excavation for Water Works observation at no additional cost to the Water Works.

- G. Allow no more than 100 feet of trench to be open at one time; install appurtenances and backfill as work progresses.

Part 3.03 – Trench Protection

Add the following new C.

- C. In addition to maintaining OSHA requirements for trench and excavation safety, special attention must be given to adequate sheeting, shoring, or bracing of an excavation area to ensure that existing paving and subgrade of adjacent roadway is not disturbed.

DIVISION 4 – SEWERS AND DRAINS

No modifications

DIVISION 5 – WATER MAINS AND APPURTENANCES

Section 5010 - Pipe and Fittings

Part 1.07 – Special Requirements

Add the following new paragraphs.

West Des Moines Water Works requires special considerations for pipe material in the vicinity of both existing and planned Underground Storage Tanks (UST) and Leaking Underground Storage Tanks (LUST).

What Is A Leaking Underground Storage Tank (LUST)?

An UST is a tank and associated piping with 10% or more of its volume below ground and which stored or is storing a regulated substance. A LUST is a leaking underground storage tank. A regulated substance is an element, compound or solution which, if released into the environment, may present danger to the public health or welfare, or the environment and includes the following:

- any petroleum or petroleum based substances (motor fuels, petroleum solvents, lubricants, used oil, etc.);
- any substance that exhibits hazardous characteristics defined in the Resource Conservation and Recovery Act (RCRA) hazardous waste regulations –or–
- any substance regulated under the Comprehensive Environmental Response, Compensation and Liability Act of 1980 (CERCLA).

How does a LUST site affect approval for new water service connections?

Section 8.1.2 of the Ten State Standards for Water Main Materials for permeation by organic compounds requires where distribution systems are installed in areas of groundwater contaminated by organic compounds, a) pipe and joint materials which do not allow permeation of the organic compounds shall be used and b) non-permeable materials shall be used for all portions of the system including pipe, joint materials, hydrant leads, and *service connections*. All new water services larger than 2" diameter that are located within a 500' radius of a LUST site will be required to be ductile iron pipe with nitrile gaskets. All 2" and smaller services must be type K Copper.

How Do I Get Information About A Specific LUST Site?

LUST sites can be added or removed at any time. To obtain current data, you may use the IDNR's website (www.iowadnr.gov/mapping/index.html). The search should be for all sites within a 1,000 foot radius of the project site. Write down the LUST site number(s) for all of the circles which fall within your project area.

Provide the LUST site numbers to the IDNR Records Center to request Utility Company Notification and associated plume maps for each LUST site. Contact information is as follows: Iowa DNR Records Center, Iowa Department of Natural Resources, 502 E 9th Street, Des Moines, IA 50319; phone: 515-242-5818; fax: 515-281-8895; e-mail: dnr.records@dnr.iowa.gov

Once you receive the information back from the IDNR Records Center, you will need to submit to WDMWW for review. This information will give more exact locations for the contamination plume(s).

The project must be at least 200' away from the edge of the contamination plume in order to use PVC pipe. If your project site falls within a LUST site, you will be required to use DI pipe w/nitrile gaskets for services larger than 2". WDMWW requires type K copper for 2" and smaller services. Any reference in the LUST documentation to a site being "cleared for PVC pipe" does NOT mean new PVC pipe is allowed on the site, but rather that PVC water lines were either not present or not considered to be at-risk receptors when the LUST site was evaluated.

For the purposes of the above requirements, USTs are considered to be a LUST with a zero foot contamination plume, measured from the outside edge of the tank or any granular bedding material.

Part 1.08 – Measurement and Payment

Add the following new E – G.

E. Connection to Existing System:

1. **Measurement:** Each connection will be counted.
2. **Payment:** Payment will be at the unit price for each connection.
3. **Includes:** Unit price includes, but is not limited to necessary isolation of existing water main, dewatering, excavation, and backfill. This item also includes miscellaneous pieces of pipe and fittings as needed to connect to the existing system.

F. Abandon Existing Water Main:

1. **Measurement:** Lump Sum item; no measurement will be made.
2. **Payment:** Payment will be at the lump sum price for Abandon Existing Water Main
3. **Includes:** Excavation, dewatering, disconnection from existing system, backfill, and surface restoration at the location of the disconnection.

G. Abandon Existing Water Service:

1. **Measurement:** Each abandonment will be counted.
2. **Payment:** Payment will be at the unit price for each abandonment.
3. **Includes:** Unit price includes, but is not limited to existing surfacing removal, excavation, dewatering, and disconnection from the existing system, installation of a Stainless Steel Full Circle Repair Clamp, backfill, and surface restoration at the location of the disconnection.

Part 2.01 – Water Main

Delete C. Prestressed Concrete Cylinder Pipe

Part 2.02 – Bolts for Water Main and Fittings

Add the following new A.4

4. Provide Cor-Blue or Cor-Ten nuts and bolts for all bolted water main connections on valves, specialty fittings and items.

Delete B and replace with the following new B.

B. Other Bolts and Nuts: Only as approved by the Water Works.

Part 2.03 – Fittings

Delete A.1 and add the following new A.1

1. Joint Type:

- a. For all pipe sizes, use restrained mechanical joint system. Provide follower gland using breakaway torque bolts to engage thrust restraint.
 1. Minimum pressure rating same as connecting pipe. For fittings between dissimilar pipes, the minimum pressure rating is the lesser of the two pipes.
 2. Suitable for buried service.
 3. Joint restraint system to be field installable, field removable, and re-installable.
- b. Restrained mechanical joint system to be:
 1. MEGALUG Series 2000PV Series or STAR StarGrip 4000 Series for Polyvinyl Chloride Pipe (PVC)
 2. MEGALUG Series 1100 Series or STAR StarGrip 3000 Series for Ductile Iron Pipe (DIP)
- c. Use of alternate restraint systems must be approved by the Water Works.

Add the following new E.

E. Stainless Steel Repair Clamp: Use for service line abandonment or as directed by the Water Works.

1. Pre-approved manufacturers: Smith Blair 261 Series, or approved equal.
2. Sleeve width to be a minimum of 12”

Part 2.05 – Pipeline Accessories

Delete B.5 and add the following new B.5

5. **Tracer Wire Station:** AA Manufacturing Tracer Wire Receptacle, Model TW-18, or an approved equal.

Part 2.07 – Water Service Pipe and Appurtenances

Delete B and add the following new B.

B. Materials

1. **Copper Pipe:** For all service piping two (2) inch diameter and smaller.
 - a. Comply with ASTM B 88.
 - b. Wall Thickness: Type K.
2. **Ductile Iron Pipe (DIP):**
 - a. As specified in Section 5010, 2.01. Polyethylene wrap is required.
3. **Polyvinyl Chloride Pipe (PVC) Pipe:**
 - a. As specified in Section 5010, 2.01.
4. **Other Materials:** None allowed.

Delete C and add the following new C.

C. Appurtenances: Use only "No Lead" Brass. Use the following series, or approved equal.

- | | |
|---------------------------------|---|
| 1. Corporation valve: | A.Y. McDonald Mfg. Co. – 74701B-22 Series |
| 2. Curb valve (Stop): | A.Y. McDonald Mfg. Co. – 76100-22 Series |
| 3. Curb valve boxes (Stop Box): | A.Y. McDonald Mfg. Co. – 5601 Series |
| 4. Compression coupling: | A.Y. McDonald Mfg. Co. – 74758-22 |
| 5. Water service saddles: | Smith-Blair, Inc. – 317 Service Saddle |

Part 3.01 – Pipe Installation

Delete A.8 and replace with the following new A.8.

8. Install restrained joints and concrete thrust blocks on all fittings.

Add the following new B.1.a.

- a. Water Main pipe shall use bedding class P-1 per SUDAS Figure SW-104 unless otherwise specified in the contract documents.

Part 3.06 – Tracer System Installation

Add the following new A.1.

1. Use Solid Steel Copper Conductor or Bimetallic Copper Clad Steel Conductor for open-cut applications. Use only Bimetallic Copper Clad Steel Conductor for trenchless applications.

Part 3.10 – Water Service Stub

Add the following new A.1 and A.2.

1. Maximum service length to building shall be 100 feet (as measured from the property line) or 150 feet (as measured from the water main) – whichever is more restrictive. Services exceeding this length require a meter pit. Refer to West Des Moines Water Works Water Service Line and Metering Specifications for additional information.
2. Unless otherwise approved by the Water Works, service stubs shall be installed after the water main Testing and Disinfection required by Section 5030.

Add the following new D – E.

D. Water Works will provide corporation valves and water service saddles. Water Works will provide curb valves and curb valve boxes for installation by Contractor. Applicable Water Works fees shall apply. Contact Water Works to schedule a minimum of one (1) working day prior to requested installation.

1. The Water Service Connection fees shall not apply for Water Works Reconstruction Projects.

E. Special Requirements for Water Works Reconstruction Projects

1. Coordinate all water service pipe reconstruction work with Water Works and impacted property owner.
2. Provide new copper water service pipe as required; connect to new corporation valve in main and to new curb valve; connect to existing water service pipe with compression coupling.
 - a. The point of connection between existing pipes and new pipes shall be as close as practical to the existing curb valve box.
 - b. Contractor responsible for finding usable existing pipe within 10 feet of initial excavation for connection; if usable pipe cannot be found within 10 feet, contact the Water Works for further direction.

Figure 5010.102 (WM-102) – Tracer System

Delete Figure and replace with Figure attached hereto.

Section 5020 – Valves, Hydrants and Appurtenances

Part 1.07 – Special Requirements

Add the following new A – C.

A. Tapping Sleeve and Valves (12” diameter and smaller):

1. Water Works will perform the tap. The Contractor shall contact Water Works a minimum of one (1) working day prior to installation of the Tapping Sleeve and Valve to schedule crews.
2. Contractor Responsibility: Traffic Control, Excavation, Shoring, Dewatering, Cleaning pipe, Procurement and Installation of Tapping Sleeve and Valve, Bedding, Backfill.
3. Water Works Responsibility: Observe pressure test and tap the Water Main.

B. Tapping Sleeve and Valves (larger than 12” diameter):

1. The Contractor or Subcontractor will procure all materials, provide all equipment, and perform all labor associated with and including the tap. West Des Moines Water Works will witness the tapping of the main. The Contractor shall contact Water Works a minimum of one (1) working day prior to installation of the Tapping Sleeve to schedule.

C. Tapping Sleeve Pressure Test: Water Works staff shall witness the pressure test performed by the Contractor on all tapping sleeves and valves prior to allowing the side cut.

Part 1.08 – Measurement and Payment

Add the following to the end of Paragraph B.3.

Refer to Section 5020, Paragraph 1.07 for Special Requirements.

Delete Paragraph C.3 and replace with the following new C.3:

3. **Includes:** Unit price includes, but is not limited to, the fire hydrant, barrel extensions sufficient to achieve proper bury depth of anchoring pipe and height of fire hydrant above finished grade, and components to connect the fire hydrant to the water main, including anchor tee, anchor pipe, fittings, thrust blocks, porous backfill material, and fire hydrant gate valve and appurtenances, except tapping valve assembly if used.

Add the following new I & J.

I. Abandon Existing Water Valve:

1. **Measurement:** Each abandoned valve will be counted.
2. **Payment:** Payment will be at the unit price for each type of abandonment
3. **Includes:** Excavation, backfill, and surface restoration. Water Works reserves the first right of refusal on removed valve and appurtenances. Work also includes all labor, equipment and materials necessary for the following:
 - a. Valves – Remove valve box
 - b. Valve Manhole – Remove valve manhole

J. Remove Existing Fire Hydrant Assembly:

1. **Measurement:** Each abandoned hydrant will be counted.
2. **Payment:** Payment will be at the unit price for each removal.

3. Includes: Excavation, backfill, and surface restoration. Water Works reserves the first right of refusal on removed hydrant and appurtenances. Work also includes all labor, equipment and materials necessary for the following:

- a. Fire Hydrant Assembly – Remove Fire Hydrant, shoe, valve box, and hydrant lead. When main is to remain in service, this item also includes the removal of the anchoring tee and replacement with straight pipe.

Part 2.01 – Valves

Delete A.2 and replace with the following A.2:

- 2. Direction of Opening:** The opening direction is counterclockwise as viewed from the top.

Delete A.3.a and replace with the following A.3.a:

- a. For buried installations, use mechanical joints per AWWA C111. Comply with Section 5010 for joint type, nuts and bolts.

Add the following B.1.a.

- a. **Manufacturers:** Approved gate valves
 1. American Flow Control – Series 2500
 2. Clow – Model 2638
 3. EJ – FlowMaster
 4. Other manufacturers may be considered on a case-by-case basis at the sole discretion of Water Works. Submit supporting materials for approval prior to bid.

Delete D.2.e

Delete D.5 and replace with the following D.5:

5. Outlet: Mechanical Joint (MJ)

Part 2.02 – Fire Hydrant Assembly – Delete B. and replace with the following new B.

- B. Manufacturers:** Approved fire hydrants
 1. Clow – Medallion
 2. Waterous – Pacer Model WB-67-250
 3. Other manufacturers may be considered on a case-by-case basis at the sole discretion of Water Works. Submit supporting materials for approval prior to bid.

Delete C.6 and replace with the following new C.6.

C. Features:

6. Items to be specified:

- a. **Operating Nut:** Pentagon shaped, 1-1/2 inch point to flat operating nut.
- b. **Pumper Nozzle:** One, 4-1/2 inches in diameter
- c. **Nozzle Threads:** National Standard threads
- d. **Main valve nominal opening size:** 5-1/4 inch diameter
- e. **Bury Depth:** Match water main depth, but not less than five feet.
- f. **Internal parts:** All threaded internal parts exposed to water shall consist of bronze. All cotter pins, drive pins, bolts, and screws exposed to water shall consist of stainless steel or brass.
- g. **Other Items:**
 1. Do not furnish chains with nozzle caps.
 2. Furnish hydrant and hydrant extension bury tags.
 3. A maximum of one (1) hydrant extension shall be allowed per hydrant.

Delete D and replace with the following new D.

D. Painting:

1. Shop coating according to AWWA C502. Hydrants to be delivered to the site in a factory applied yellow finish. Hydrants delivered in another color may be rejected by the Water Works.
2. Above grade exterior coating to be Sherwin Williams High Performance Acrylic paint – SHER-CRYL HPA, B66-300 series, Gloss Safety Yellow.

Delete E and replace with the following new E.

E. External Bolts and Hex Nuts:

1. Below Grade – Stainless steel according to ASTM A 193, Grade B 8.
2. Above Grade – Plated steel per manufacturer's recommendation.

Part 2.03 – Appurtenances

Delete C. and replace with the following C.

- C. Valve Stem Extension:** Use requires prior authorization of the Water Works. Where used, provide as necessary to raise 2 inch operating nut to within 3 feet of the finished grade. Stem diameter according to valve manufacturer's recommendations, but not less than 1 inch.

Part 3.03 – Fire Hydrant Assembly

Delete A and replace with the following new A.

- A. Install according to the contract documents. Use the "Typical Plan" unless "Alternate Plan" is indicated.

Add the following new D.4.

4. Ensure that break flange and break coupling are at joint between barrel and nozzle section when extensions are installed.

Add the following new G.

- G. After hydrant is installed and is ready for use, Touch up paint as necessary to cover paint damaged during installation.

Figure 5020.20 (WM-201) – Fire Hydrant Assembly

Delete Figure and replace with Figure attached hereto.

Section 5030 – Testing and Disinfection

Part 3.01- Sequence of Testing and Disinfection

Delete A and add the following new A.

- A. Continuous-Feed Method (After Water Main Installation):** The sequence of testing and disinfection may be modified with approval of the Water Works.
1. Perform initial flush.
 2. Perform pressure and leak testing.
 3. Perform disinfection.
 4. Flush after disinfection.

Delete B and add the following new B.

- B. Tablet Method (Concurrent with Water Main Installation) or Slug Method (After Water Main Installation):** Use these methods only if approved by the Water Works.

DIVISION 6 – STRUCTURES FOR SANITARY AND STORM SEWERS

No modifications

DIVISION 7 – STREETS AND RELATED WORK

Section 7010 – Streets and Related Work

Part 3.06 – Use of Pavement

Revise the minimum Compressive Strengths shown in Table 7010.01 to 4,000 psi.

Section 7030 – Recreation Trails, Sidewalks and Driveways

Part 1.07 – Special Requirements

Add the following new A – E.

- A. Construct Recreational Trails, Sidewalks, and Driveways in accordance with current PROWAG/SUDAS requirements. Panels which do not meet the requirements shall be replaced at no additional project cost.
- B. Do not replace “carriage walks”; restore area with turf as specified. Replacement trails, sidewalks and driveways shall match existing horizontal dimensions and surface texture. Minimum thickness of replaced panels is six (6) inches or the existing thickness plus two (2) inches, whichever is greater. Reconstruct joints to match existing work.
- C. Reinforcement
 1. Where no existing reinforcement is present, drill and dowel into adjacent slabs to prevent settlement. Install 1/2” diameter rebar and maintain 2” clearance from ground surface.
 2. Where existing reinforcement is present, drill and dowel into existing sidewalk and match existing reinforcement pattern. Reinforcement must span between panels and overlap a minimum of half of each panel’s length.
- D. Driveway Approaches:
 1. Portland Cement Concrete, Asphalt Cement Concrete, and gravel driveway approaches shall be replaced with Portland cement concrete.
 2. Driveway approaches having no connecting driveway in adjacent private property will not be replaced.
- E. Additional Removal due to Damaged Panels
 1. Additional surfacing damaged by the Contractor through carelessness or poor workmanship shall be removed and replaced by the Contractor at no additional project cost. Full panel replacement is required.

Section 7040 – Pavement Rehabilitation

Part 1.07 – Special Requirements

Add the following new A and B.

- A. Additional Removal due to Damaged Panels

1. Additional surfacing damaged by the Contractor through carelessness or poor workmanship shall be removed and replaced by the Contractor at no additional project cost. Full panel replacement is required.
- B. Pavement Cross Section
1. Pavement Type – All pavements shall be replaced with a like pavement section to the removed pavement.
 2. Full Depth Patches – The thickness of full depth patches shall equal existing pavement thickness plus two (2) inches.

DIVISION 8 – TRAFFIC CONTROL

No modifications

DIVISION 9 – SITE WORK AND LANDSCAPING

Section 9010 - Seeding

Part 1.07 – Special Requirements

Add the following new 1.07.

- A. Water Usage – The West Des Moines Water Works will provide the Contractor water on City of West Des Moines and West Des Moines Water Works Projects free of charge, with the following requirements:
1. The water is to be metered and the Contractor must obtain the meter from the West Des Moines Water Works. A refundable meter deposit is required.
 2. The Contractor will abide by the rules and regulations of bulk water usage as prepared by West Des Moines Water Works.
 3. The Contractor will only use hydrants that have been previously approved by the West Des Moines Water Works for bulk water usage.
 4. The quantity of water provided on the Project free of charge for irrigation purposes will be limited to 870 gallons of water per square (100 square feet) of seed installed as part of the project. Additional water usage shall be the sole responsibility of the Contractor. Additional water shall be paid for at the current West Des Moines Water Works bulk water rate. No additional free water will be provided for areas requiring re-seeding.
 - a. To receive the water credit, the Contractor shall provide written measurements to the Water Works for all seeded areas. Measurements and calculations are subject to verification.

Section 9020 – Sodding

Part 1.07 – Special Requirements

Add the following new 1.07.

- A. Water Usage – The West Des Moines Water Works will provide the Contractor water on City of West Des Moines and West Des Moines Water Works Projects free of charge, with the following requirements:
1. The water is to be metered and the Contractor must obtain the meter from the West Des Moines Water Works. A refundable meter deposit is required.
 2. The Contractor will abide by the rules and regulations of bulk water usage as prepared by West Des Moines Water Works.

3. The Contractor will only use hydrants that have been previously approved by the West Des Moines Water Works for bulk water usage.
4. The quantity of water provided on the Project free of charge for irrigation purposes will be limited to 870 gallons of water per square (100 square feet) of sod installed as part of the project. Additional water usage shall be the sole responsibility of the Contractor. Additional water shall be paid for at the current West Des Moines Water Works bulk water rate. No additional free water will be provided for areas requiring re-sodding.
 - a. To receive the water credit, the Contractor shall provide written measurements to the Water Works for all sodded areas. Measurements and calculations are subject to verification.

Part 1.08 – Measurement and Payment

Add the following new B.

- B. Surface Restoration
 1. **Measurement:** Lump Sum item; no measurement will be made.
 2. **Payment:** Payment will be at the lump sum price for Surface Restoration.
 3. **Includes:** Fine grading, topsoil, sod, preparation of sod and sodbed, fertilizer, watering, 30-day maintenance period and cleanup. Also included is any sod replacement during the maintenance period.

Part 3.06 Maintenance

Delete A. and replace with the following new A.

- A. Begin maintenance immediately following installation of sod and continue for a period until the sod is well established with sod rooted in place. The maintenance period will be for 30 days, or until the acceptance criteria have been met, whichever is longer.

Delete B.3. Mowing.

Part 3.08 Acceptance

Add the following new A.2.a.

- a. At Water Works discretion, up to 10-15 percent of the total sodded area may contain limited amounts of weeds, undesirable grass species, disease and insects.

DIVISION 10 – DEMOLITION

No modifications

DIVISION 11 – MISCELLANEOUS

No modifications

- ① Extend tracer wire up fire hydrant barrel to internal terminals of tracer wire station and back down. Refer to WM-201 for details of fire hydrant assembly.
- ② Clamp tracer wire to ground rod at system termination points.
- ③ Run wire up the outside of the valve box. Notch the top of valve box and run wire into box below lid.
- ④ Bring tracer wire to surface if valve is more than 25 feet from the hydrant

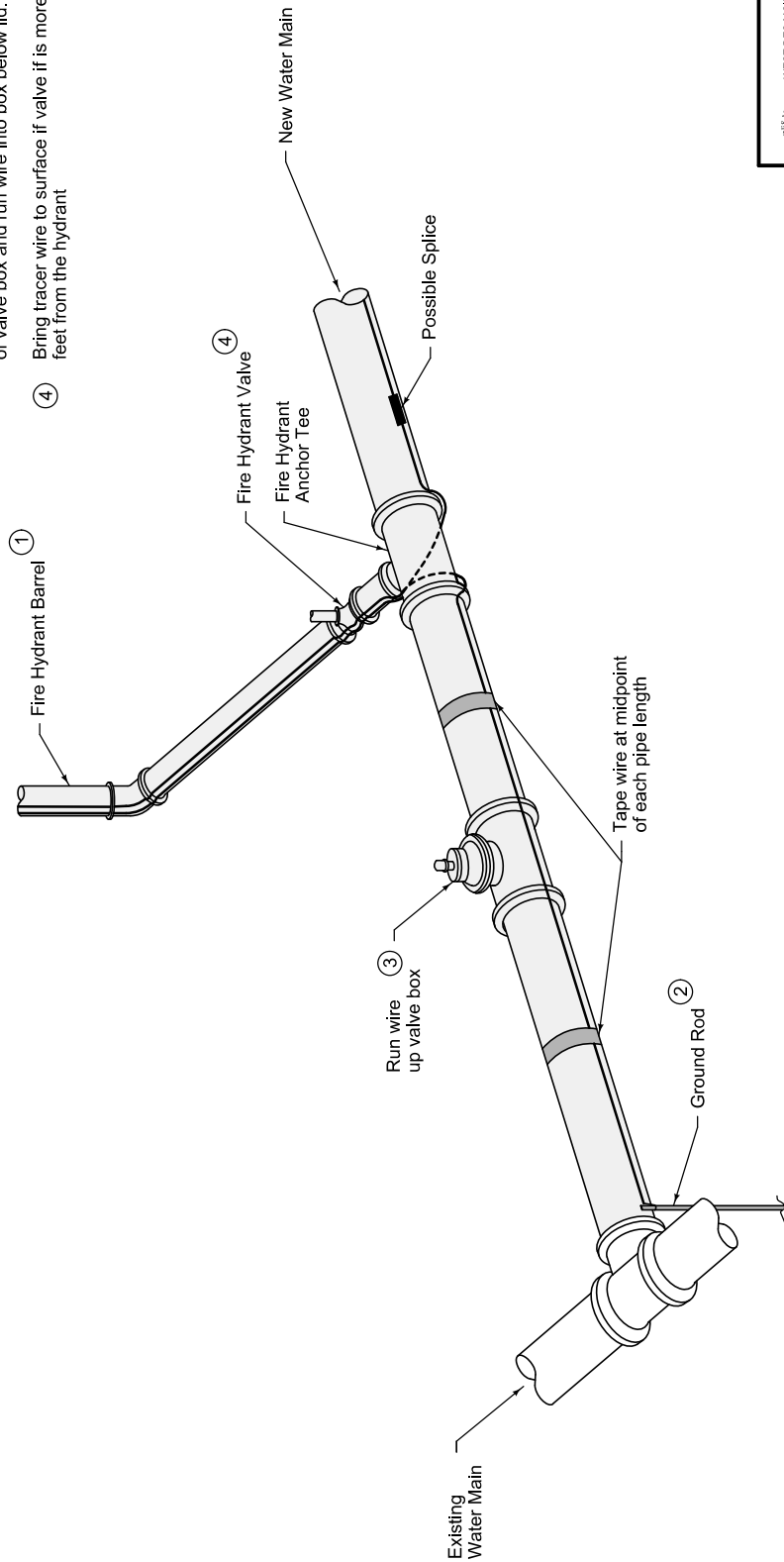

TYPICAL INSTALLATION

 WEST DES MOINES WATER WORKS 4200 Mike Clark Parkway, Suite 110 West Des Moines, Iowa 50265 515-222-3510 Office 515-222-3465 Plant	REVISION NEW 11-16-2015
	WM-102 SHEET 1 of 1
REVISIONS: Modifications for West Des Moines Water Works System.	
TRACER SYSTEM	

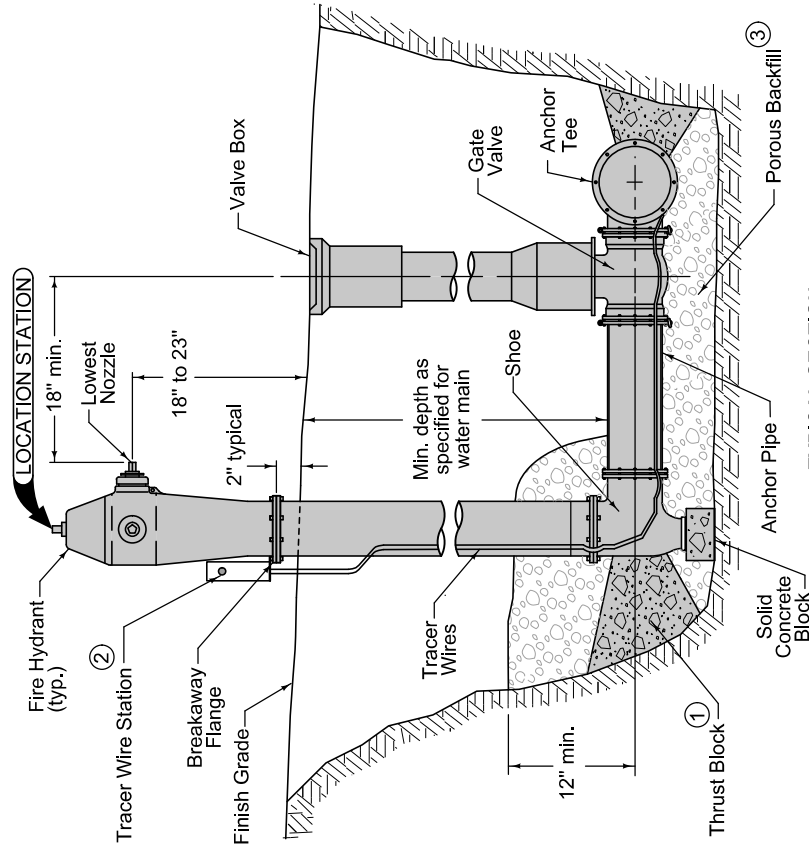
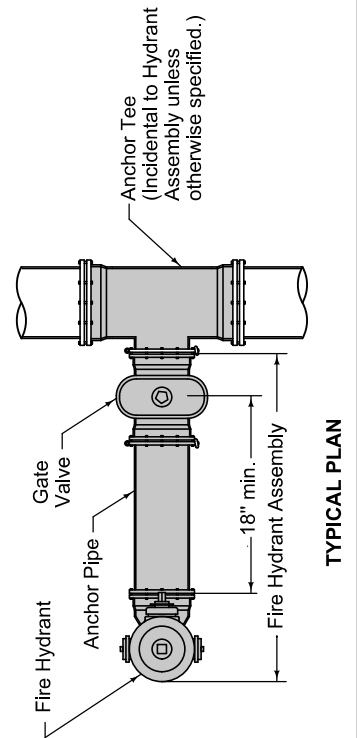
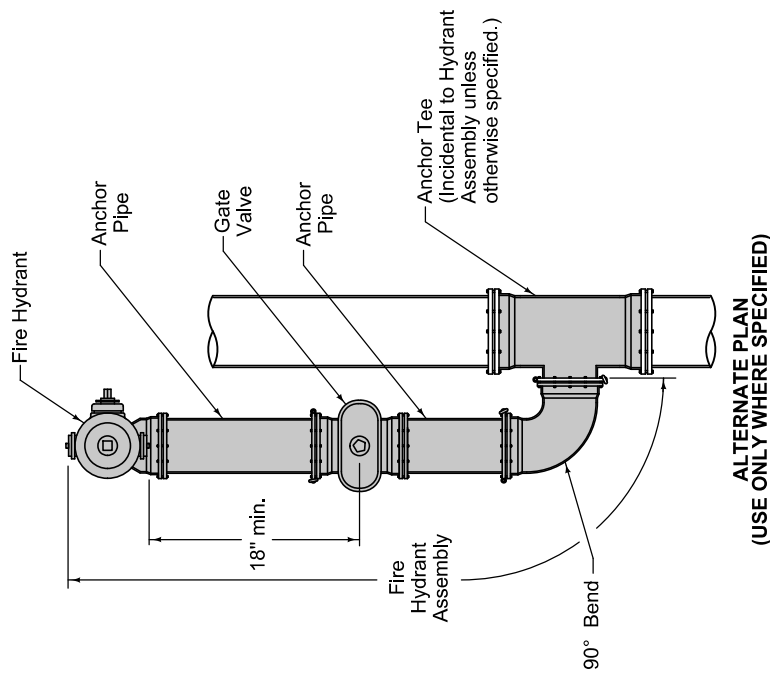

Use ductile iron pipe with restrained mechanical joints for fire hydrant assembly and anchor tee.

- ① Do not cover drain holes or tracer wire.
- ② Mount Tracer Wire Station to the side away from the large nozzle. Protect tracer wire in conduit to a minimum depth of 6" below grade.
- ③ Porous Backfill to be 1" Clean Crushed Stone or other material as approved by the Water Works.

	WEST DES MOINES WATER WORKS 4200 W. Main Street, Suite 110 West Des Moines, Iowa 50265 515-222-3510 Office 515-222-3465 Plant	REVISION NEW 11-16-2015 WM-201 SHEET 1 of 1
	REVISIONS: Modifications for West Des Moines Water Works System.	
		FIRE HYDRANT ASSEMBLY

